STRUCTURAL DESIGN 2

INTRODUCTION: Advantages and Disadvantages of Steel structures, Loads and Load combinations, Design considerations, Limit State Method (LSM) of design, Failure criteria for steel, Codes, Specifications and section classification.

BOLTED CONNECTIONS: Introduction, Behavior of Bolted joints, Design strength of ordinary Black Bolts, Design strength of High Strength Friction Grip bolts (HSFG), Pin Connections, Simple Connections, Moment resistant connections, Beam to Beam connections, Beam and Column splices, Semi rigid connections

UNIT 1 - INTRODUCTION

Why Structural **Design** Courses?

Anyone managing the construction process needs a basic understanding of the engineer's environment and the basic understanding of how a structure behaves. Constructors must be able to address a number of technical questions at the project site including structural issues that sometimes are not addressed by the **design** professionals. Since the safety of construction workers as well as the strength and stability of structures during the construction phase is of paramount importance, construction managers need this knowledge.

Structural Design

- Definition: Determination of overall proportions and dimensions of the supporting framework and the selection of individual members.
- Responsibility: The structural engineer, within the constraints imposed by the architect(number of stories, floor plan,..) is responsible for structural design
- Safety (the structure doesn't fall down)
- Serviceability (how well the structure performs in term of appearance and deflection)
- Economy (an efficient use of materials and labor)

Alternatives

- Several alternative designs should be prepared and their costs compared

Types of Load

- Dead Loads (permanent; including self-weight, floor covering, suspended ceiling, partitions,..)
- Live Loads (not permanent; the location is not fixed; including furniture, equipment, and occupants of buildings)
- Wind Load (exerts a pressure or suction on the exterior of a building)

Types of Load Continued

- Earthquake Loads (the effects of ground motion are simulated by a system of horizontal forces)
- Snow Load (varies with geographical location and drift)
- Other Loads (hydrostatic pressure, soil pressure)

Types of Load Continued

- If the load is applied suddenly, the effects of IMPACT must be accounted for.
- If the load is applied and removed many times over the life of the structure, FATIGUE stress must be accounted for

Design Specifications

- Provide guidance for the design of structural members and their connections.
- They have no legal standing on their own, but they can easily be adopted, by reference, as part of a building code.
- American Concrete Institute (ACI 318-99) Building Code Requirements for Structural Concrete
- National Design Specifications for Wood Construction by American Forest and Paper Association.

Structural **Steel**

- **Steel** is an alloy of primarily iron, carbon (1 to 2%) and small amount of other components (manganese, nickel, ...)
- Carbon contributes to strength but reduces ductility.

Steel Properties

- The important characteristics of **steel** for **design** purposes are:
 - yield stress (F^y)
 - ultimate stress (F^u)
 - modulus of elasticity (E)
 - percent elongation (ϵ)
 - coefficient of thermal expansion (α)

Standard Cross-Sectional Shapes

Refer steel table

Design Philosophies

- Allowable Stress **Design** Method (ASD)
- Load and Resistance Factor **Design** (LRFD)

A member is selected such that the max stress due to working loads does not exceed an allowable stress.

- It is also called elastic **design** or working stress **design**.
 - allowable stress = yield stress / factor of safety
 - actual stress \leq allowable stress

LRFD –Load and Resistance Factor Design

- A member is selected such that its factored strength is more than the factored loads.
 - $\Sigma(\text{loads} \times \text{L factors}) \leq \text{resistance} \times \text{R factor}$
- Each load effect (DL, LL, ..) has a different load factor which its value depends on the combination of loads under consideration.

Load Factors

- The values are based on extensive statistical studies
 - DL only 1.4D
 - DL+LL+SL (LL domin.) 1.2D+1.6L+0.5S
 - DL+LL+SL (SL domin.) 1.2D+0.5L+1.6S
 - In each combination, one of the effects is considered to be at its “lifetime” max value and the others at their “arbitrary point in time “ values.

Resistance Factor

- The resistance factors range in value from 0.75 to 1.0 depending on the type of resistance (tension, bending, compression, ..)
- These factors account for uncertainties in material properties, **design** theory, and fabrication and construction practices.

History

- ASD has been the primary method used for **steel design** since the first AISC specifications was issued in 1923.
- In 1986, AISC issued the first specification for LRFD.
- The trend today is toward LRFD method, but ASD is still in use.

Advantages of LRFD

- It provides a more uniform reliability in all structures subjected to many types of loading conditions. It does not treat DL and LL as equivalent, thereby leading to a more rational approach.
 - It provides better economy as the DL make up a greater percentage on a given structure. Because DLs are less variable by nature than live loads, a lower load factor is used.

This may lead to a reduction in member size and therefore better economy

STEEL AS A STRUCTURAL MATERIAL

General

Structural steel is a material used for steel construction, which is formed with a specific shape following certain standards of chemical composition and strength. They can also be defined as hot rolled products, with a cross section of special form like angles, channels and beams/joints. There has been an increasing demand for structural steel for construction purposes in the United States and India.



Measures are been taken by the structural steel authority for ready availability of structural steel on time for the various projects. The people at every level are working hard to realize the purpose of producing steel on time, like, service centers, producers, fabricators and erectors along with the general contractors, engineers and architects are all working hand in hand. Steel has always been more preferred to concrete because steel offers better tension and compression thus resulting in lighter construction. Usually structural steel uses three dimensional trusses hence making it larger than its concrete counterpart. There are different new techniques which

enable the production of a wide range of structures and shapes, the procedures being the following:

- High-precision stress analysis
- Computerized stress analysis
- Innovative jointing

The structural steel all over the world pre-dominates the construction scenario. This material has been exhaustively used in various constructions all over the world because of its various specific characteristics that are very much ideally suited for construction. Structural steel is durable and can be well molded to give the desired shape to give an ultimate look to the structure that has been constructed. There is a mention of The Super dome situated in the United States and The Fukuoka Dome of Japan; both speak the unique language of the unique capabilities of the structural steel.



Types of structural steel:

Various types of structural steel sections and their technical specifications are as follows:

- **Beams**
- **Channels**
- **Angles**
- **Flats**

Steel Beams

Steel Beams is considered to be a structural element which mainly carries load in flexure meaning bending. Usually beams carry vertical gravitational force but are also capable of carrying horizontal loads generally in the case of an earthquake. The mechanism of carrying load in a beam is very unique, like; the load carried by a beam is transferred to walls, columns or girders which in turn transfer the force to the adjacent structural compression members. The joists rest on the beam in light frame constructions.

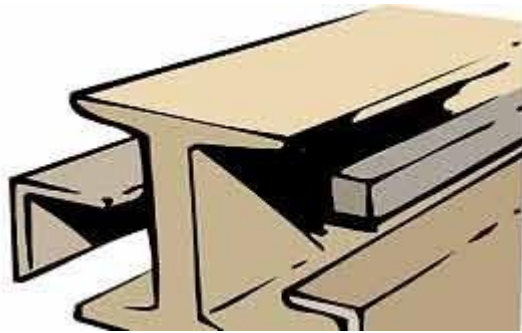

The beams are known by their profile meaning:

- The length of the beam
- The shape of the cross section
- The material used

The most commonly found steel beam is the I beam or the wide flanged beam also known by the name of universal beam or stouter sections as the universal column. Such beams are commonly used in the construction of bridges and steel frame buildings. The most commonly found types of steel beams are varied and they are mentioned below:

- I beams
- Wide flange beams
- HP shape beams

Typical characteristics of beams

Beams experience tensile, sheer and compressive stresses internally due to the loads applied to them. Generally under gravity loads there is a slight reduction in the original length of the beam. This results in a smaller radius arc enclosure at the top of the beam thus showing compression. While the same beam at the bottom is slightly stretched enclosing a larger radius arc due to tension. The length of the beam midway and at the bends is the same as it is not under tension or compression and is defined as the neutral axis. The beam is completely exposed to shear stress above the support. There are some reinforced concrete beams that are completely under compression, these beams are called pre-stressed concrete beams and are built in such a manner to produce a compression more than the expected tension under loading conditions. The pre-stressed concrete steel beams have the manufacturing process like, first the high strength steel tendons are stretched and then the beam is cast over them. Then as the concrete begins to cure the tendons are released thus the beam is immediately under eccentric axial loads. An internal moment is created due to the eccentric axial load which in turn increases the moment carrying capacity of the beam. Such beams are generally used in highway and bridges.

Materials Used

In today's modern construction the beams are generally made up of materials like:

- Steel
- Wood
- Reinforced concrete

Steel Channels:

Steel channels are used ideally as supports and guide rails. These are roll-formed products. The main metal used for making channels is steel along with aluminum. There are certain variations that are available in the channels category, the categorization is mainly on the shape of the channel, the varieties are mentioned below:



- **J channels:** This kind of channel has two legs and a web. One leg is longer. This channel resembles the letter-J.
- **Hat channels:** This channel has legs that are folded in the outward direction resembling an old fashioned man's hat.
- **U channels:** This most common and basic channel variety. It has a base known as a web and two equal length legs.
- **C channels:** In this channel the legs are folded back in the channel and resemble the letter-C. C channels are known as rests.
- **Hemmed channels:** In this kind of channel the top of the leg is folded hence forming double thickness.

There are other variations of channels that are available, which are customized according to the customer's needs.

Application

Steel channels are subjected to a wide array of applications. The application fields are:

- Construction
- Appliances
- Transportation
- Used in making Signposts
- Used in wood flooring for athletic purposes

-
- Used in installing and making windows and doors

A major variant of the channel is the mild steel channel. Such channels are generally used in heavy industries. They are used in the heavy machinery industry and automotive industry too.

Steel Angle:

A steel angle is long steel with mutually vertical sides. The steel angles are the most basic type of roll-formed steel. The most commonly found steel angles are formed at a 90 degree angle and has two legs of equal length. The sides are either equal or of different sizes.



There are certain variations in the steel angles depending on it's basic construction. The variations are like; if one leg is longer than the other then it is known as L angle. If the steel angle is something different from 90 degrees then it is known as V angle. In some steel angles, double thickness is achieved by folding the legs inward. If the steel angle has same sides then it means that it has identical width. The steel angles are made according to the strength that is required for the different structures for construction purposes.

- **Applications**

the steel angle finds an application in a number of things, they are mentioned below:

- Used in framing
- Used in trims
- For reinforcement
- In brackets
- Used in transmission towers
- Bridges
- Lifting and transporting machinery

-
- Reactors
 - Vessels
 - Warehouses
 - Industrial boilers
 - Structural steel angles are used in rolling shutters for fabricating guides for strength and durability.

Steel Flats:

Flats are actually thin strips of mild steel having the thickness of the strip commonly varying from 12mm to 10mm but thicker flats than this are also available. Steel flats are produced by the utilization of relatively smooth, cylindrical rolls on rolling mills. Generally the width to thickness ratio of flat rolled products is fairly large. The steel flat bars are manufactured using advanced thickness control technology for controlled thicknesses. The hi-tech machineries enable the production of top grade steel flat bars with superlative flatness and controlled thickness. This product is highly customized and the specific sizes according to the client's requirement are produced. After production the flat steels are subjected to a variety of finishes like, painting and galvanizing. The flat carbon steel is a hot or cold rolled strip product also known as a plate product. These plate products have a size variation between 10mm to 200mm and the thin flat rolled flat rolled product's size varies from 1 mm to 10 mm.



Applications

The steel flats are used in a wide array of applications. The varied applications are listed below:

-
- Railway parts
 - Ordnance factories
 - Hand tools
 - Engineering industries
 - Auto components- two-wheeler, four-wheeler, commercial vehicles
 - Domestic white goods products
 - Office furniture's
 - Heart pacemakers
 - Tin cans
 - Press working

Advantages of steel as a structural material:

Structural steel sections are usually used for construction of buildings, buildings, and transmission line towers (TLT), industrial sheds and structures etc. They also find in manufacturing of automotive vehicles, ships etc.

Steel exhibits desirable physical properties that make it one of the most versatile structural materials in use.

Its great strength, uniformity, light weight, easy of use, and many other desirable properties makes it the material of choice for numerous structures such as steel bridges, high rise buildings, towers, and other structure.

Elasticity: steel follows hooks law very accurately.

Ductility: A very desirable of property of steel, in which steel can withstand extensive deformation without failure under high tensile stresses, i.e., it gives warning before failure takes place.

Toughness: Steel has both strength and ductility.

Additions to existing structures: Example: new bays or even entire new wings can be added to existing frame buildings, and steel bridges may easily be widened.

Disadvantages of steel as a structural material:

Although steel has all these advantages as structural material, it also has many disadvantages that make reinforced concrete as a replacement for construction purposes.

For example steel columns sometimes cannot provide the necessary strength because of buckling, whereas RCC columns are generally sturdy and massive, i.e., no buckling problem occurs.

Many disadvantages of steel can be summarized below:

Maintenance cost: Steel structures are susceptible to corrosion when exposed to air.

Fire proofing cost: steel is an incombustible material; however, its strength is reduced tremendously at high temperature due to common fires.

Fatigue: The strength of structural steel member can be reduced if this member is subjected to cyclic loading.

Brittle fracture: under certain conditions steel loses its ductility, and brittle fracture may occur at places of stress concentration. Fatigue type loadings and very low temperature trigger the situation.

Limit state design:

Refer IS:800-2009 in detail and other text bookd

BOLTED CONNECTIONS

A bolt may be defined as a metal pin with a head at one end and a shank threaded at the other end to receive a nut as in Fig 1.0(a). Steel washers are usually provided under the bolt as well as under the nut to serve two purposes:

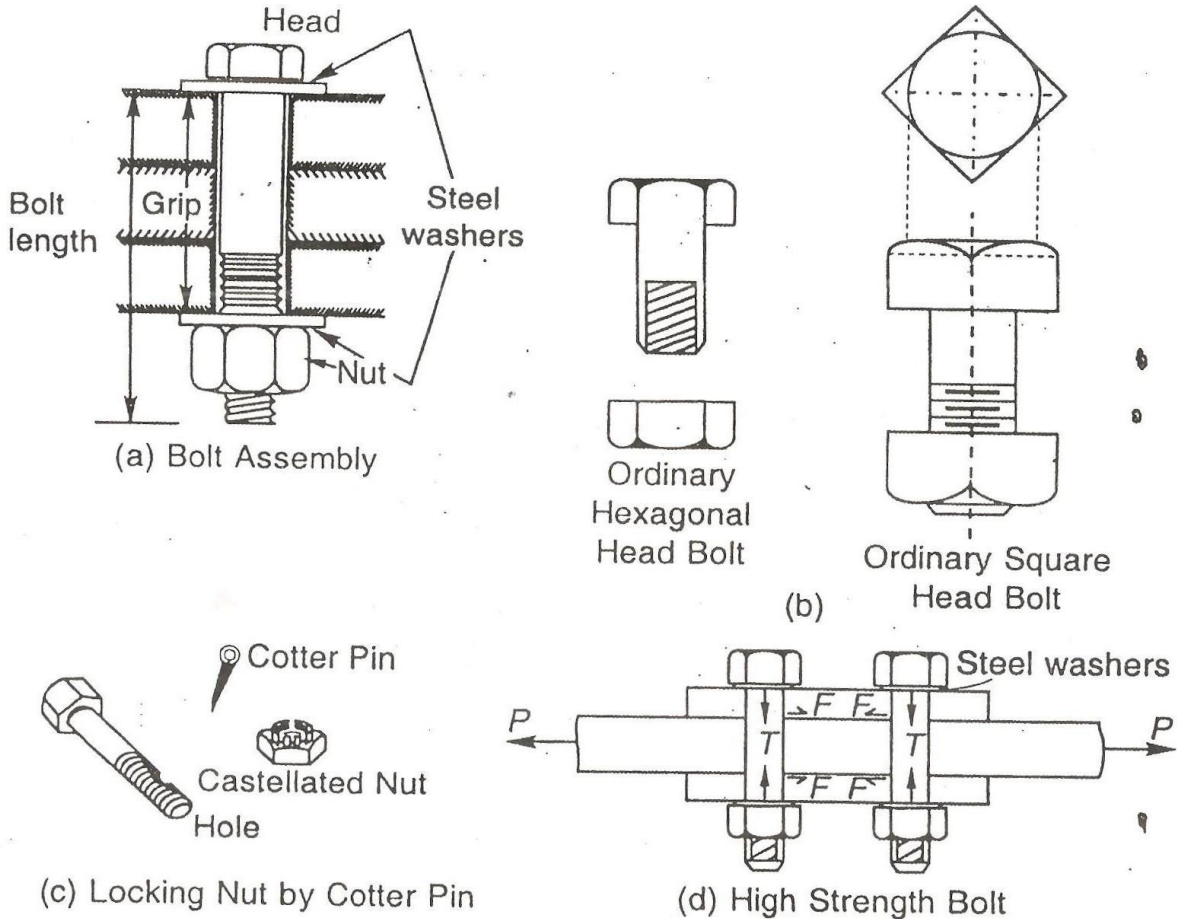

Fig. 2.12 Bolted Joints

1. To distribute the clamping pressure on the bolted member, and
2. To prevent the threaded portion of the bolt from bearing on the connecting pieces.

In order to assure proper functioning of the connection, the parts to be connected must be tightly clamped between the bolt between the bolt head and nut. If the connection is subjected

vibrations, the nuts must be locked in position. Bolted connections are quite similar to riveted connections in behavior but have some distinct advantages as follows:

1. The erection of the structure can be speeded up, and
2. Less skilled persons are required.

The general objections to the use of bolts are:

1. Cost of material is high: about double that of rivets.
2. The tensile strength of the bolt is reduced because of area reduction at the root of the thread and also due to stress concentration.
3. Normally these are of a loose fit excepting turned bolts and hence their strength is reduced.
4. When subjected to vibrations or shocks bolts may get loose.

Uses

1. Bolts can be used for making end connections in tensions and compression member.
2. Bolts can also be used to hold down column bases in position.
3. They can be used as separators for purlins and beams in foundations, etc.

Types

There are several types of bolts used to connect the structural elements. Some of the bolts commonly used are:

- a) Unfinished bolts
- b) Turned bolts

-
- c) Ribbed bolts
 - d) High strength bolts
 - e) Interference bolts

UNFINISHED BOLTS

Unfinished bolts are also called ordinary, common, rough or black bolts. They are used for light structures (purlins, bracings, etc.) under static loads. They are not recommended for connections subjected to impact load, vibrations and fatigue. Bolts are forged from low carbon rolled steel circular rods, permitting large tolerances. Ordinary structural bolts are made from mild steel with square or hexagonal head, as shown in Fig 1.0(b). Square heads cost less but hexagonal heads give a better appearance, are easier to hold by wrenches and require less turning space. The bolt hole is punched about 1.6mm more than the bolt diameter. The nuts on bolts are tightened with spud wrenches, producing little tension. Therefore, no clamping force is induced on the sections jointed. Sometimes a hole is drilled in the bolt and a cotter pin with a castellated nut is used to prevent the nut from turning on the bolt, as shown in Fig 1.0(c). The connections with unfinished bolts are designed in a similar way as all the riveted connections except that the permissible stresses are reduced to account for tolerances provide on shank and threaded portion of the bolts. The requirements regarding pitch and edge distance are same as that for rivets. The permissible stresses are as given in Table 8.1 of I.S:800-1984.

TURNED BOLTS

These are similar to unfinished bolts, with the differences that the shank of these bolts is formed from a hexagonal rod. The surfaces of the bolts are prepared carefully and are machined to fit in the hole. Tolerances allowed are very small. These bolts have high shear and bearing resistance as compared to unfinished bolts. However, these bolts are obsolete nowadays. The specifications for turned bolts are given in I.S:2591-1969.

RIBBED BOLTS

These are also called fluted bolts. The head of the bolt is like a rivet head. The threaded and nut are provided on the other end of the shank. From the shank core longitudinal ribs project making the diameter of the shank more than the diameter of the hole. These ribs cut grooves into the connected members while tightening and ensure a tight fit. These bolts have more resistance to

vibrations as compared to ordinary bolts. The permissible stresses for ribbed are same as that for rivets.

HIGH STRENGTH BOLT

These bolts are called friction grip bolts. These are made from bars of medium carbon steel. Their high strength is achieved through quenching and tempering processes or by alloying steel. Steel washers of hard steel or carburized steel are provided as shown in Fig1.0 (d), to evenly distribute the clamping pressure on the bolted member and to prevent the threaded portion of the bolt from bearing on the connecting pieces. If the bolts are tightened by the turn of nut method, the nut is made snug and is tightened a half turn more by hand wrenches, then the washers are not required. The vibrations and impact resistance of the joint is also improved. The nut and head of the bolts are kept sufficiently large to provide an adequate bearing area. The specifications for high strength bolts are laid in I.S:3757-1972 and I.S: 4000-1967. These bolts have a tensile strength several times that of the ordinary bolts. High strength bolts have replaced rivets and are being used in structures, such as high rise buildings, bridges, machines etc. Due to their distinct advantages and vital use, high strength bolts are discussed below in some detail.

Advantages of high strength bolts

High strength friction grip (HSFG) bolts have replaced the rivets because of their distinct advantages as discussed below. However, the material cost is about 50% greater than that of ordinary bolts and special workmanship is required in installing and tightening these bolts.

1. These provide a rigid joint. There is no slip between the elements connected
2. Large tensile stresses are developed in bolts, which in turn provide large clamping force to the elements connected. High frictional resistances is developed providing a high static strength the joint.
3. Because of the clamping action, load is transmitted by friction only and the bolts are not subjected to shear and bearing.

-
4. The frictional resistance is effective outside the hole and therefore lesser load is transmitted through the net section. Thus, the possibility of failure at the net section is minimized.
 5. There are no stress concentrations in the holes; therefore, the fatigue strength is more.
 6. The tension in bolts is uniform. Also the bolts are tensioned up to proof load hence; the nuts are prevented from loosening
 7. Few persons are require to make the connections, thus cost is reduced.
 8. Noise nuisance is not there as these bolts are tightened with wrenches.
 9. The hazard of fire is not there and there is no danger of tossing of the bolt.
 10. Alterations can be done easily.
 11. For some strength, lesser number of bolts are required as compared to rivets which brings overall economy.

Principles of high strength bolts

The shank of the high strength bolts does not fully fill the hole. So shear and bearing are not the criteria for load transmission as is in the case of rivets, which fill the hole completely. The nut is tightened to develop a clamping force on the plates which is indicated as the tensile force T in the Bolt. This tension should be about 90% of proof load. When a shear load is applied to the joint no slip will occur until the shear load exceeds the frictional resistance between the elements jointed. When shear load exceeds the frictional resistance a slip occurs. On further increase of this load, the gradual slipping brings the bolt in contact with the plate edges.

The horizontal frictional forces F, is induced in the joints which is equal to the tensile force T, as in Fig.1.0(d), in the bolts multiplied by the coefficient of friction.

$$F = \mu T$$

This frictional force F should exceed the applied force P on the member.

μ = Coefficient of friction or slip factor, is defined as ratio of the load per effective interface required to produce slip in a pure shear joint to the proof load induced in bolt. When the element surfaces are free from paint, dust, etc. its value is 0.45.

PIN CONNECTIONS

When two structural members are connected by means of a cylindrical shaped pin, the connection is called a pin connection. Pins are manufactured from mild steel bars with diameters ranging from 9 to 330 mm. Pin connections are provided when hinged joints are required, i.e., for the connection where zero moment of free rotation is desired. Introduction of a hinge simplifies the analysis by reducing indeterminacy. These also reduce the secondary stresses. These connections cannot resist longitudinal tension. For satisfactory working it is necessary to minimize the friction between the and members connected. High grade machining is done to make the pin and pin hole surface smooth and frictionless. Pins are provided in the following cases:

1. Tie rod connections water tanks and elevated bins
2. As diagonal bracing connections in beams and columns
3. Truss bridge girders
4. Hinged arches
5. Chain-link cables suspension bridges

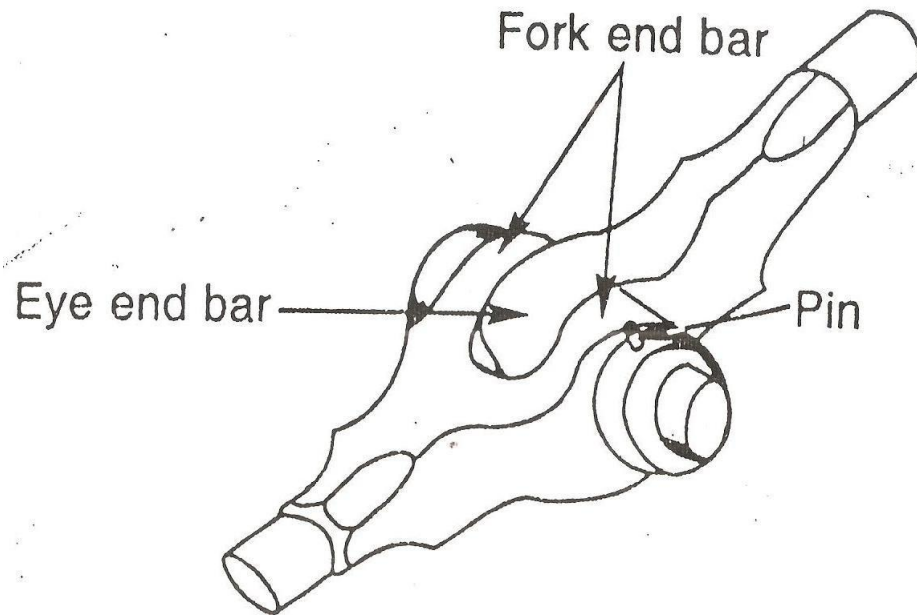

Fig. 2.13 Pin Connection

Various types of pins used for making the connections are forged steel pin, undrilled pin and dilled pin. To make a pin connection, one end of the bar is forged like a fork and a hole is drilled in this portion. The end of the other bar to be connected is also forged and an eye is made. A hole is drilled into it in such a way that it matches with the hole on the fork end bar. The eye bar is inserted in the jaws of the fork end and a pin is placed. Both the forged ends are made octagonal for a good grip. The pin in the joint is secured by means of a cotter pin or screw, as shown in Fig. 2.13.

FAILURE OF BOLTED JOINTS

The bolted joint may fail in any of the following six ways, out of which some failures can be checked by adherence to the specifications of edge distance. Therefore, they are not of much importance, whereas the others require due consideration.

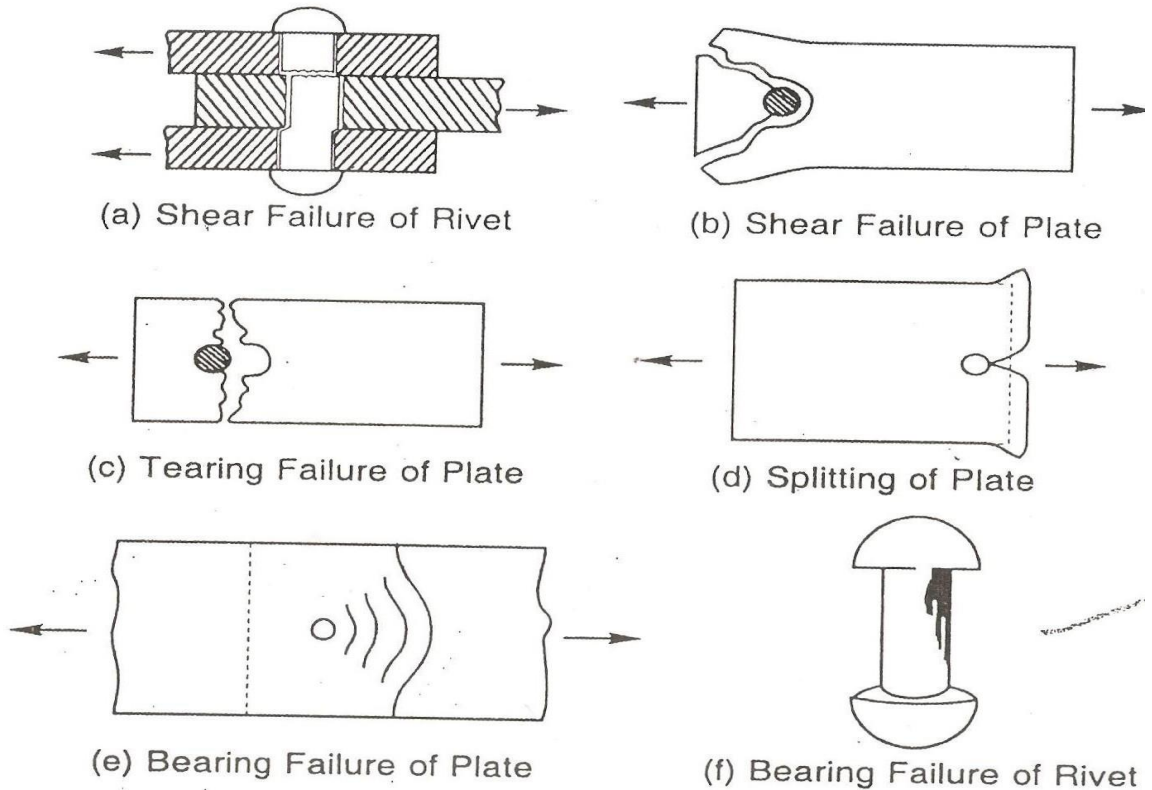

Fig. 2.3 Failure of Riveted Joints

Shear failure of bolts (Fig. 2.3 (a))

The shear stress in the bolt may exceed the working shear stress in the bolt. Shear stresses are generated because the plates slip due to applied forces.

Shear failure of plates (Fig. 2.3(b))

The internal pressure of overdriven (shank length more than the grip) bolts placed at a lesser edge distance than specified causes this failure. This can be checked by providing proper edge distance between the center of the hole and the end of the plate as specified by I.S.800.

Tension or tearing failure of plates (Fig. 2.3(c))

The tensile stress in the plate at the net cross-section may exceed the working tensile stress. Tearing failure occurs when bolts are stronger than the plates.

Splitting of plates (Fig. 2.3(d))

Bolts may have been placed at a lesser edge distance than required causing the plates to split or shear out.

Bearing failure of plates (Fig. 2.3(e))

The plate may be crushed when the bearing stress in the plate exceeds the working bearing stress.

Bearing failure of bolts (Fig. 2.3(f))

The bolt is crushed around the half circumference. The plate may be strong in bearing and the heaviest stressed plate may press the bolt.

TYPES OF RIVETED JOINTS

There are two types of riveted joints: lap joint and butt joint.

Simple Connections—Riveted, Bolted and Pinned Connections □

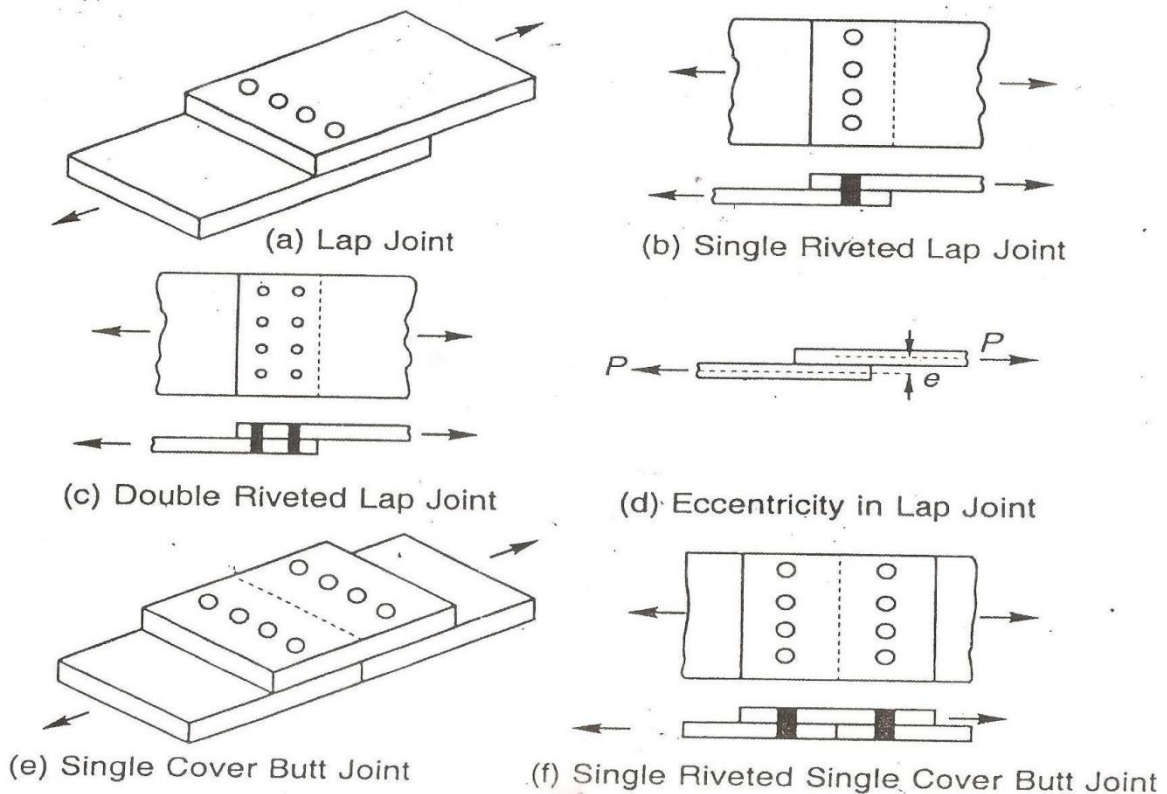

Lap joint The two members to be connected are overlapped and connected together. Such a joint is called a lap joint as in Fig. (a). A single riveted lap joint and a double riveted lap joint are shown in Figs (b,c) respectively. The load in the lap joint has eccentricity, as the centre of gravity of load in one member and the centre of gravity of load in the second member are not in the same line, as shown in Fig. 2.2(d). Therefore, a couple is formed which causes undesirable bending in the connection and the rivets may fail in tension. To minimize the effect of bending in lap joints at least two rivets in a line should be provided. Also, due to the eccentricity the stresses are distributed un-evenly across the contact area between rivets and the members to be connected. This puts a limitation on the use of lap joints.

Butt joint The two members to be connected are placed end to end. Additional plate/plates provided on either one or both sides, called cover plates and are connected to the main plates

as in Figs 2.2(e,h). If the cover plate is provided on one side as in Figs 2.2(f), (g), it is called a single cover butt joint but if the cover plates are provided on both the sides of main plates it is called a double cover butt joint as shown in Fig. 2.2.(i),(j). It is more desirable to provide a butt joint than a lap joint for two main reasons:

In the case of double cover butt joint the total shear force to be transmitted by the members is split into two parts and the force acts on each half as shown in Fig. 2.2(k). But in the case of lap joint (Fig. 2.2(l), there is only one plane on which the force acts and therefore the shear carrying capacity of a rivet in a butt joint is double that of a rivet in a lap joint.

In the case of a double cover butt joint, eccentricity of force does not exist and hence bending is eliminated, whereas it exists in the case of a lap joint.

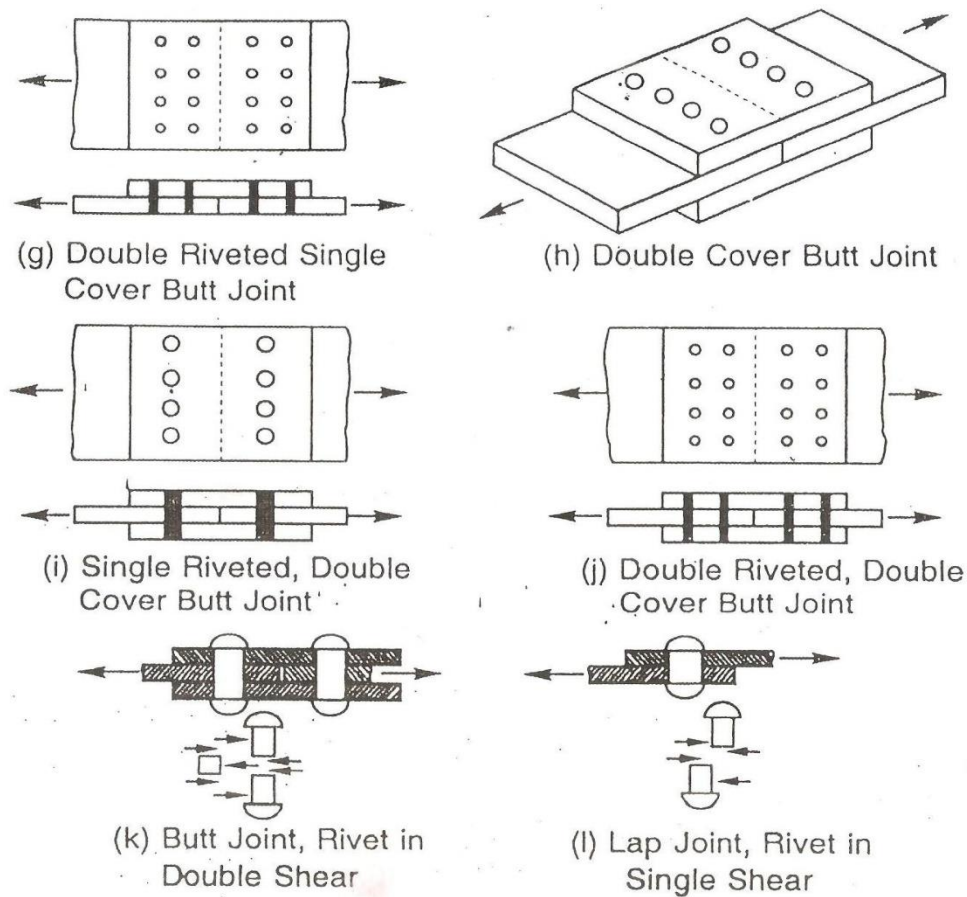

Fig. 2.2 Types of Riveted Joints

Design of Bearing Bolts Subjected to Eccentric Loading Causing Moment in the Plane Perpendicular to the Plane of Group of Bolts.

This type of connection is shown in Fig. 3.23. Referring to Fig. 3.28, let P be factored load at an eccentricity 'e'. Then the section is subjected to a direct shear force P and moment $M = Pxe$.

If there are 'n' numbers of bolts in the connection, direct design shear force on each bolt is given by,

$$V_{sb} = P/n$$

The moment causes tension in top side and compression in the bottom side. On tension side, only bolts resist load but on compression side entire contact zone between the columns and the connecting angle resist the load. Hence the neutral axis will be much below in these connections. It is assumed to lie at a height of $1/7$ th of the depth of the bracket, measured from the bottom edge of the angle.

The variation of the force is as shown in Fig. 3.28(c).

The tensile force in a bolt T_{bi} is proportional to its distance y_i from the line of rotation.

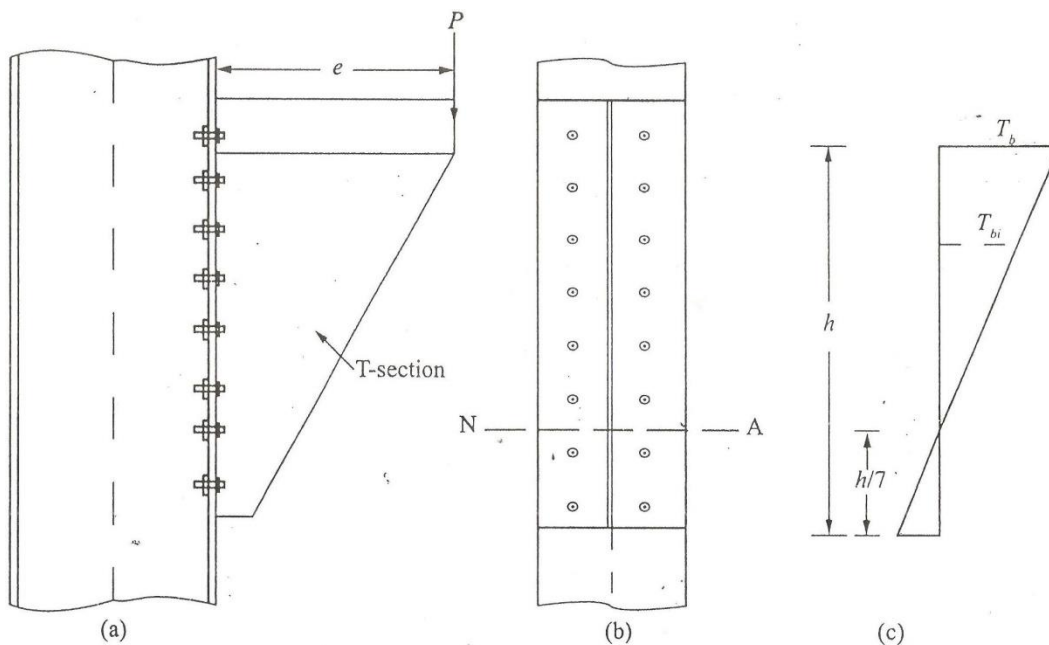

Figure 3.28

$$T_{bi} \propto y_i$$

$$= ky_i, \text{ where } k \text{ is constant.}$$

$$k = T_{bi} / y_i$$

Total moment of resistance M' provided by bolts in tension.

$$M' = \sum T_{bi} y_i = \sum k y_i^2$$

$$M' = k \sum y_i^2 = \frac{T_{bi}}{y_i} \sum y_i^2$$

$$T_{bi} = \frac{M' y_i}{\sum y_i^2}$$

Or

Total tensile force in bolts

$$T = \sum T_{bi} = \frac{M' \sum y_i}{\sum y_i^2}$$

For equilibrium,

Total tensile force = total compressive force

$$T = C = \frac{M' \sum y_i}{\sum y_i^2}$$

Taking moment about neutral axis,

$$M = M' + C \frac{2h}{3}$$

$$= M' + \frac{2h \sum y_i}{21 \sum y_i^2}$$

$$M' = \frac{1}{1 + \frac{2h \sum y_i}{21 \sum y_i^2}}$$

Tensile force T_{dh} in extreme bolt can be found.

This equation gives the moment resisted by the bolts in tension from which the maximum tensile force in the extreme bolt T_b can be calculated. Then the design required is

$$\frac{V}{V_{dh}} + \frac{T}{T_{dh}} \leq 1.0$$

Steps to be followed in the design

Step 1: Select nominal diameter 'd' of bolts.

Step 2: Adopt a pitch(p) of 2.5d to 3.5d for bolts.

Step 3: Bolts are to be provided in two vertical rows. Number of bolts necessary in each row is computed from the expression.

$$n = \sqrt{\frac{6M}{(2V)P}}$$

Where M is the moment on the joint and V is the design strength of bolt.

Step 4: Find the direct shear and tensile forces acting on the extreme bolt. If it is HSFG bolted connection adds prying force [Ref. Fig. 3.28] to direct tension. Check whether the interaction formula is satisfied.

Example 3.11

Design a suitable bolted bracket connection of a ISHT-75 section attached to the flange of a ISHB 300 at 577N/m to carry a vertical factored load of 600 kN at an eccentricity of 300 mm. Use M24 bolts of grade 4.6

Solution:

For M24 bolts of grade 4.6,

D=24mm, d_o=27mm, f_{ub}=400N/mm²

Thickness of flange of ISHT 75 (from steel table) = 9mm

For ISHB 300 @ 577 N/m, thickness of flange = 10.6mm

Therefore, thickness of thinner member = 9mm

$$\begin{aligned} \text{Design strength of bolt in single shear} &= \frac{1}{1.25} \left[\frac{400}{\sqrt{3}} \left(0 + 0.78 X \frac{\pi}{4} X 24^2 \right) \right] \\ &= 65192 \text{ N} \end{aligned}$$

Design strength of bolts in bearing:

Minimum edge distance e = 1.5x d_o = 1.5x24 = 40.5 mm

Minimum pitch p = 2.5d = 2.5x24 = 60 mm

Provide e = 50 mm and p = 70mm

$$K_b \text{ is minimum of } \frac{e}{3d_o}, \frac{p}{3d_o} - 0.25, \frac{f_{ub}}{f_u} \text{ and } 1.0$$

$$\text{i.e., minimum of } \frac{50}{3 \times 27}, \frac{70}{3 \times 27} - 0.25, \frac{400}{410} \text{ and } 1.0$$

$$\therefore K_b = 0.6412$$

Design strength of bolts in bearing against 9 mm thick web of Tee section

$$= \frac{1}{1.25} \times 2.25 \times k_b \times d \times f_u$$

$$= \frac{1}{1.25} \times 2.25 \times 0.6142 \times 24 \times 9 \times 410$$

$$= 109333 \text{ N} > 65192 \text{ N}$$

∴ Design strength of bolts $V = V_{db} = 65192 \text{ N}$

Design tension capacity of bolts

$$T_{bi} = \frac{0.90 \times f_{ub} \times A_n}{1.25} < \frac{f_{yb} \times A_{sb}}{1.10}$$

$$T_{bi} = \frac{0.90 \times 400}{1.25} \times 0.78 \times \frac{\pi}{4} \times 24^2 < \frac{240 \times \frac{\pi}{4} \times 24^2}{1.10}$$

$$= 98703 \text{ N}$$

Using two rows of bolting, approximately number of bolts required in each row

$$n = \sqrt{\frac{6M}{(2V)P}} = \sqrt{\frac{6 \times 600 \times 1000 \times 300}{(2 \times 65192 \times 70)}} = 10.87$$

Provide 11 bolts in each row as show in Fig

$$h = 50 + 70 \times 10 = 750 \text{ mm}$$

$$h/7 = 107.14 \text{ mm}$$

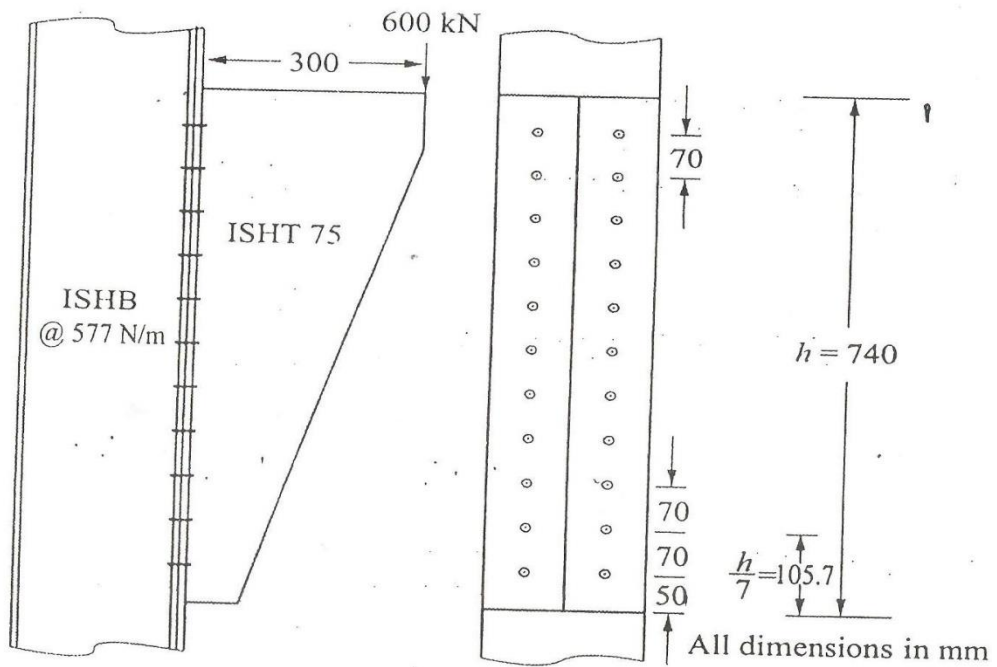
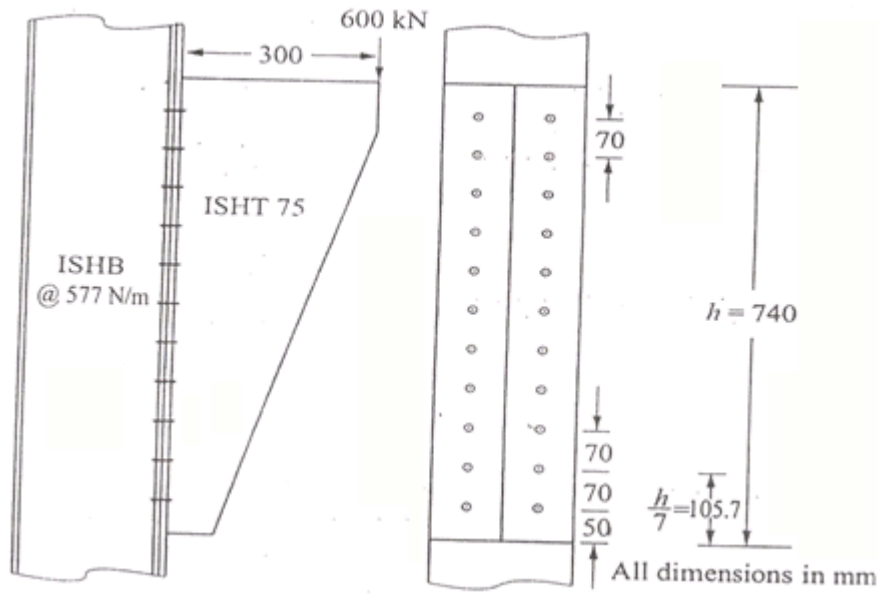

Figure 3.29

i.e. neutral axis lies between 1st and 2nd bolts.

∴ y of second bolt = $(50+70)-107.14=12.86$ mm

$$\therefore \sum y = 2 \times 3278.6 \text{ mm}$$

$$\therefore \sum y^2 = 2 \times 1479142 \text{ mm}^2$$

Total moment resisted by bolts in tension

$$M' = \frac{1}{1 + \frac{2h \sum y_i^2}{21 \sum y_i^2}} = \frac{600 \times 1000 \times 300}{1 + \frac{2 \times 750 \times 2 \times 3278.6^2}{21 \times 2 \times 1479142}}$$

$$= 155397179 \text{ N-mm}$$

Tensile force in extreme bolt due to bending moment

$$T_b = \frac{M' y_i}{\sum y_i^2} = \frac{155397179}{2 \times 1479142} \times 642.86 = 33769 \text{ N}$$

Direct shear force

$$V_{sb} = \frac{600 \times 1000}{2 \times 11} = 27273 \text{ N}$$

$$\text{Check by interaction formula} = \frac{V_{sb}^2}{V_{db}^2} + \frac{T_b^2}{T_{db}^2}$$

$$= \frac{27273^2}{65192^2} + \frac{33769^2}{98703^2}$$

$$= 0.292 < 1.0$$

Hence the bolts are safe. Provide bolts as shown in Fig. 3.29.

SHEAR CAPACITY OF HSFG BOLTS

As stated in Fig, these are the bolts made of high tensile steel which are pretensioned and then provided with nuts. The nuts are clamped also. Hence resistance to shear force is mainly by friction.

There are two types of HSFG bolts. They are parallel shank and waisted shank type. Parallel shank type HSFG bolts are designed for no-slip at serviceability loads. Hence they slip at higher loads and slip into bearing at ultimate loads. Hence such bolts are checked for their bearing strength at ultimate load. Waisted shank HSFG bolts are designed for no slip even at ultimate load and hence there is no need to check for their bearing strength.

$$V_{nsf} = \mu_f n_e K_h F_0$$

Where,

μ_f = Co-efficient of friction (Called slip factor) as specified in Table 3.1.

n_e = number of effective interfaces offering frictional resistance to this slip.

[Note: $n_e = 1$ for lap joints and 2 for double cover butt joints]

$K_h = 1.0$ for fasteners in clearance holes

$= 0.85$ for fasteners in oversized and short slotted holes and for long slotted holes located perpendicular to the slot.

$= 0.70$ for fasteners in long slotted holes loaded parallel to the slot.

F_0 = Minimum bolt tension at installation and may be taken as $A_{nb} f_0$

$$A_{nb} = \text{net area of the bolt at threads} = 0.78 \frac{\pi d^2}{4}$$

f_0 = Proof stress = $0.70 f_{ub}$

Table 3.1 Typical average value for coefficient of friction (μ_f) [Table 20 in IS 800-2007]

Sl. No.	Treatment of Surface	μ_f
1	Surface not treated	0.20
2	Surface blasted with shot or grit with any loose rust removed, no pitting	0.50
3	Surface blasted with shot or grit and hot-dip galvanized	0.7
4	Surface blasted with shot or grit and spray-metallized with zinc (thickness 50–70 μm)	0.25
5	Surfaces blasted with shot or grit and painted with ethylzinc silicate coat (thickness 30–60 μm)	0.30
6	Sand blasted surface, after light rusting	0.52
7	Surface blasted with shot or grit and painted with ethylzinc silicate coat (thickness 60–80 μm)	0.30
8	Surface blasted with shot or grit and painted with alkalizinc silicate coat (thickness 60–80 μm)	0.30
9	Surface blasted with shot or grit and spray metallized with aluminium (thickness > 50 μm)	0.50
10	Clean mill scale	0.33
11	Sand blasted surface	0.48
12	Red lead painted surface	0.1

The slip resistance should be taken as

$$V_{sf} = V_{nsf}/1.10$$

Where,

=1.10, if the slip resistance is designed at service load (Parallel shank HSFG)

=1.25, if the slip resistance is designed at ultimate load (Waisted shank HSFG).

It may be noted that the reduction factors specified (Fig. 3.11) for bearing bolts hold good for HSFG bolts also.

For commonly used HSFG bolts (Grade 8.8), yield stress $f_{yb} = 640 \text{ Mpa}$ and ultimate stress $f_{ub} = 800 \text{ N/mm}^2$

Example 3.12

Determine the shear capacity of bolts used in connecting two plates as shown in Fig.3.30

1. Slip resistance is designated at service load

2. Slip resistance is designated at ultimate load

Given:

HSFG bolts of grade 8.8 are used.

Fasteners are in clearance holes

Coefficient of friction = 0.3

Solution:

For HSFG bolts of grade 8.8,

For fasteners in clearance holes $K_h = 1.0$

Coefficient of friction $\mu_f = 0.3$

∴ Nominal shear capacity of a bolt

$$V_{nsf} = \mu_f n_c K_h F_0$$

Where

$$F_0 = 0.7 f_{ub} A_{nb}$$

$$= 0.7 \times 800 \times 0.78 \times \frac{\pi}{4} \times 20^2$$

$n_c = 2$, since it is double cover butt joint

(i) Design capacity of one bolt, if slip resistance is designated at service load

$$\begin{aligned} V_{nsf} &= 0.3 \times 2 \times 1.0 \times 137225 \\ &= 82335 \text{ N} \\ &= 82335/1.1 = 74850 \text{ N} \end{aligned}$$

Therefore design capacity of joint = 6 x 74850, since 6 bolts are used

$$\begin{aligned} &= 449099 \text{ N} \\ &= 449.099 \text{ kN} \end{aligned}$$

(ii) Design capacity of one bolt, if the slip resistance is designated at ultimate load

$$= 82335/1.25 = 65868 \text{ N}$$

Therefore design capacity of joint = 6 x 65868, since 6 bolts are used

$$= 395208 \text{ N}$$

$$= 395.208 \text{ kN}$$

In case (i), bearing strength at ultimate load should be checked. If it is low that will be the governing factor.

TENSION RESISTANCE OF HSFG BOLTS

The expression for nominal tension strength of HSFG bolts is also as that for bearing bolts. i.e,

$$T_{nf} = 0.9 X f_{ub} X A_n \leq f_{yb} A_{sb} \frac{\gamma_{mb}}{\gamma_m}$$

$$T_{df} = \frac{0.9 f_{ub} A_n}{\gamma_{mb}} \leq \frac{f_{yb} A_{sb}}{\gamma_m}$$

Where

A_n = net tensile area as specified in various parts of IS 1367, it may be taken as the area at the

$$\text{root of the thread} = 0.78 \frac{\pi}{4} d^2$$

A_{sb} = shanke area.

$$\gamma_{mb} = 1.25, \gamma_m = 1.1$$

f_{ub} for bolts of grade 8.8 is 800 MPa and $f_{yb} = 640$ MPa.

INTERACTION FORMULA FOR COMBINED SHEAR AND TENSION

If bolts are under combined action of shear and axial tension, the interaction formula to be satisfied is

$$\left(\frac{V}{V_{sf}}\right)^2 + \left(\frac{T}{T_{df}}\right)^2 \leq 1.0$$

PRYING FORCES

In the design of HSFG bolts subjected to tensile forces, an additional force, called as prying force Q is to be considered. These additional forces are mainly due to flexibility of connected plates. Consider the connection of a T-section to a plate as shown in Fig 3.31, subject to tensile force $2T_e$.

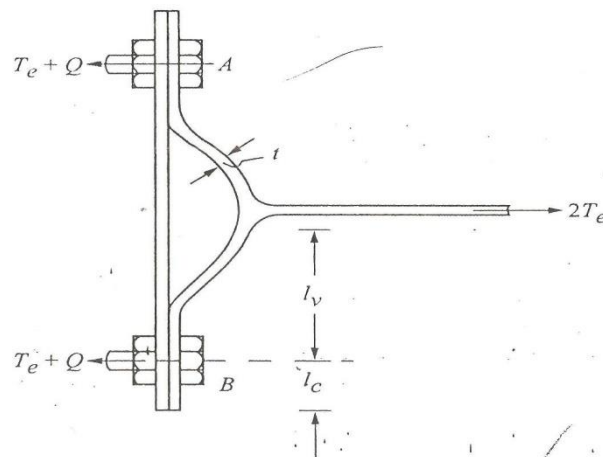

Figure 3.31

As tensile force acts, the flange of T-section bends in the middle portion and presses connecting plates near bolts. It gives rise to additional contact forces known as prying forces. During late 80s and early 90s lot of research works were published regarding assessing prying force. IS 800-2007 has accepted the following expression

$$Q = \frac{l_y}{c} T_e - \frac{\beta \eta f b t^4}{2710 l_y c}$$

Where

Q = prying force

$2T_e$ = total applied tensile force

l_y = distance from the bolt centre line to the toe of the fillet weld or to half the root radius for a rolled section.

l_c = distance between prying forces and bolt centre line and is the minimum of either the end distance or the value given by:

$$l_c = 1.1t \sqrt{\frac{\beta f_0}{f_y}}$$

$\beta = 2$ for non-pretensioned bolts and for pretensioned bolts

$\eta = 1.5$

b_e = effective width of flange per pair of bolts.

f_0 = Proof stress in consistent units

t = thickness of end plate.

Note that prying forces do not develop in case of ordinary bolts, since when bolt failure takes place contact between the two connecting plates is lost (Ref. Fig. 3.32).

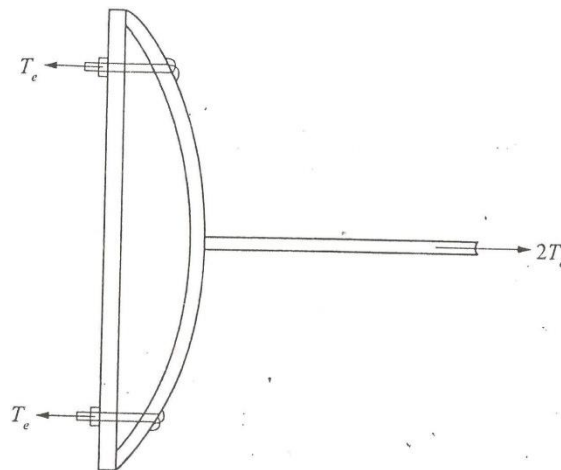

Figure 3.32

Example

The joint shown in fig has to carry a factored load of 180kN. End plate used is of size 160 mm x 40 mm x 16 mm. The bolts used are M20 HSFG of grade 8.8. Check whether the design is safe.

Solution:

Assuming 8 mm weld and edge distance 40mm,

$$l_y = 160/2 - 8 - 8 - 40 = 24 \text{ mm}$$

$$l_c = 1.1t \sqrt{\frac{\beta f_0}{f_y}}$$

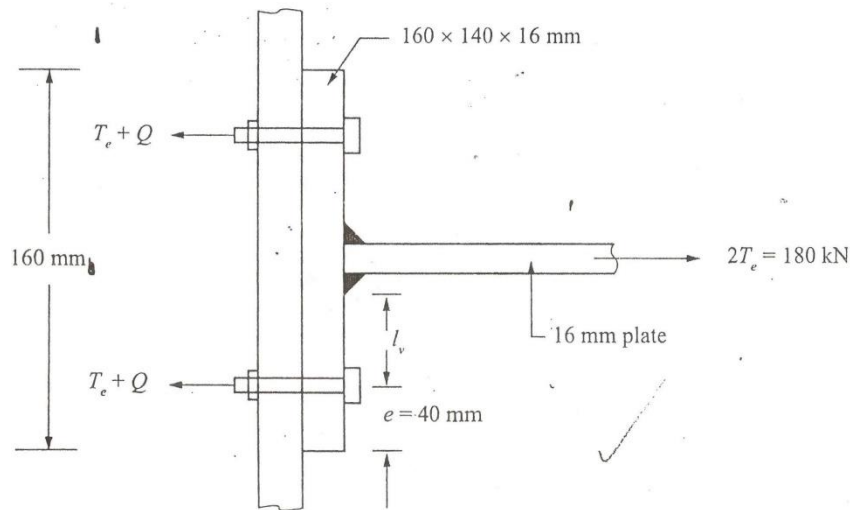

Figure 3.33

For plates, $f_0 = 0.7 f_u$, $f_u = 410 \text{ MPa}$ and $f_y = 250 \text{ MPa}$

$$l_c = 1.1 \times 16 \sqrt{\frac{1 \times 0.7 \times 410}{250}} = 18.86 <$$

< Edge distance

$$l_c = 18.86 \text{ mm}$$

Prying force is given by,

$$Q = \frac{l_y}{c} T_e - \frac{\beta \eta f b t^4}{2710 l_y^2 c}$$

$\beta = 1.0$, for pretensioned bolts.

$\eta = 1.5$

$b_e = 140\text{mm}$, $t = 16\text{mm}$.

$f_0 = 0.7 \times 800 = 560\text{MPa}$

$$Q = \frac{24}{2 \times 18.86} \times 90000 - \frac{1 \times 1.5 \times 560 \times 140 \times 16^4}{27 \times 18.86 \times 24^2}$$
$$= 40545 \text{ N}$$

Therefore tension to be resisted by the bolt

$T = T + Q = 90000 + 40545 = 130545 \text{ N}$

Tension capacity of the bolt $= \frac{0.9 f_{ub} A_{ub}}{1.25}$

$$= \frac{0.9 \times 800 \times 0.78 \times \frac{\pi}{4} \times 20^2}{1.25}$$

$= 141145 \text{ N} > 130545 \text{ N}$

Hence the design is safe.